

Features

- Input impedance $200\Omega + 560\Omega // 0.1\mu F$
- Transformerless 2-wire to 4-wire conversion
- Battery and ringing feed to line
- Off-hook and dial pulse detection
- Ring ground over-current protection
- Adjustable constant current feed
- Relay drive output
- Power VBat Denial
- Wide Operating Range
- Programmable Receive Gain

Applications

Line interface for:

- PABX
- Intercoms
- Key Telephone Systems
- Control Systems

ISSUE 4

April 1995

Ordering Information

MH88612C 20 Pin SIL Package

0°C to 70°C

Description

The SLIC provides a complete interface between a switching system and subscriber loop. Functions provided include battery feed and ringing feed to the subscriber line, 2-Wire to 4-Wire hybrid interfacing, constant current feed and dial pulse detection. The device is fabricated using thick film hybrid technology in a 20-pin single in-line package.

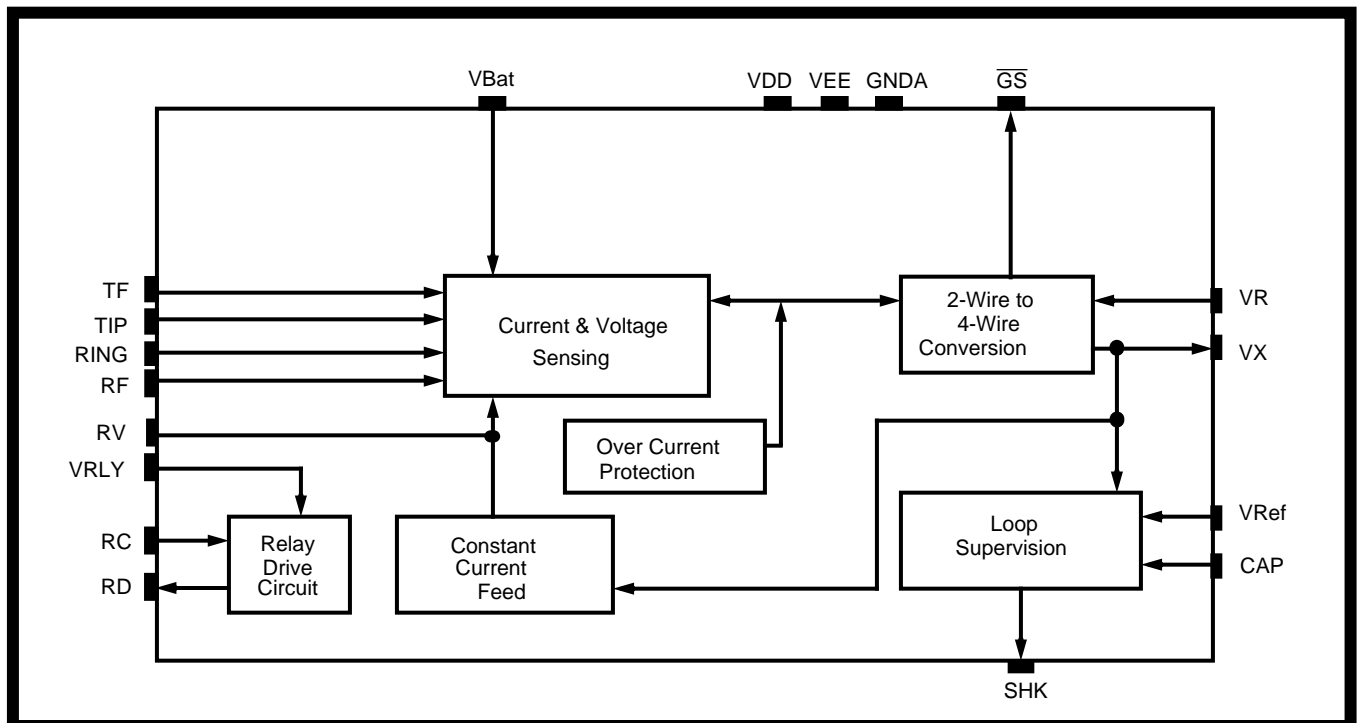

Figure 1 - Functional Block Diagram

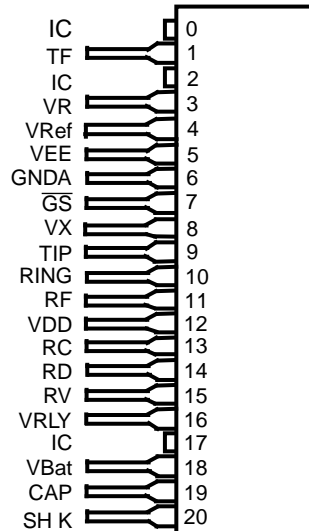

Figure 2 - Pin Connections

Pin Description

Pin #	Name	Description
0	IC	Internal Connection. No pin fitted in this position.
1	TF	Tip Feed. Connects to external diode to LPGND for protection.
2	IC	Internal Connection. No pin fitted in this position.
3	VR	Voice Receive (input) is the 4 wire analog signal to the SLIC.
4	VRef	Voltage Reference to set the constant current feed to the subscriber line. Constant current feed can be adjusted by the input voltage on the VRef. This pin can also be grounded for normal 21mA loop current.
5	VEE	Negative Power Supply voltage. (-5V).
6	GNDA	Analog Ground. (0V)
7	\overline{GS}	Gain setting (Input). A logic low at this input adds an additional -0.5dB gain in the receive direction. This gain is in addition to the gain set by the Codec. A high adds 0dB gain.
8	VX	Voice Transmit (Output) is the 4-wire analog signal from the SLIC.
9	TIP	Connects to the "Tip" lead of the telephone line.
10	RING	Connects to the "Ring" lead of the telephone line.
11	RF	Ring Feed (Input). is connected via the ring relay to either negative battery feed voltage, (RV), or ringing voltage input.
12	VDD	Positive Power Supply Voltage. (+5V)
13	RC	Relay Control (Input). Active high will apply ringing to the line.
14	RD	Output Drive Sources current when RC is at a logic high.
15	RV	Ring Feed Voltage connects to pin 11 (RF) through a normally closed relay contact.
16	VRLY	Relay voltage Supply. (+5V)
17	IC	Internal Connection. No pin fitted in this position.
18	VBat	Negative Battery Feed Supply Voltage. (-48V)
19	CAP	Connects external capacitor to ground for ring trip.
20	SHK	Switch Hook Detect (Output). Active high.

Functional Description

The SLIC performs a transformerless 2-wire to 4-wire conversion of the analog signal. The 2-wire circuit is the balanced line going to the subscriber loop, while the 4-wire circuit is the audio signal going to and from devices such as the voice codec or switching circuit. The SLIC also provides a switch hook (SHK) status output which goes high when the telephone is set off-hook.

Constant Current Feed

The SLIC employs a complex feedback circuit to supply a constant feed current to the line. This is done by sensing the sum of the voltages across the internal feed resistors and comparing it to an input reference voltage (V_{Ref}) that determines the constant feed current. If V_{Ref} (pin 4) is externally grounded, the constant current is set at 21mA. For a constant current setting between 18mA and 30mA, V_{Ref} can be set between -8.75 Vdc and -6.35 Vdc. The relationship is detailed in the formula below:

$$I_{Loop} = [-2.6(V_{Ref}) + 21.5] \text{ mA } \pm 2\text{mA}$$

Switch Hook Detection

When the DC current exceeds an internal threshold level, the switch hook (SHK) will go high. If the loop resistance is so high that V_{Bat} can no longer supply the required amount of loop current as determined by constant current supply circuit, the output of the switch hook (SHK) will go low to indicate that the loop resistance is too high and the line is on hook.

Ringing And Ring Trip Detection

In Figure 3 a ringing signal (e.g. 90 Vrms superimposed on -48 VDC) is applied to the line by disconnecting pin 15 (RV) from pin 11 (FR), and connecting the ringing voltage at pin 11 (RF) by use of the relay K1.

The SLIC can detect an off-hook condition during ringing but there is a large AC component which must be filtered out to give a true off-hook condition at SHK.

A 1 μ F capacitor connected from pin 19 (CAP) to ground will provide adequate attenuation when ringing is applied.

For applications requiring dial pulse detection the capacitor connection to ground should be controlled so that the capacitor is only connected during ringing.

During off-hook conditions (closed loop), the capacitor should be switched out. This can be performed using a transistor, relay to system drive output of a codec. Applying GNDA to Ring Trip Filter Control pin will switch in the filter, whilst removing GNDA, (with the switch in a tristate condition), will switch out the filter.

For applications using DTMF signalling, the capacitor can be permanently connected to ground.

Once an off-hook condition has been detected a logic low on the Relay Control (RC) input deactivates the relay (K1) to disconnect the ringing voltage from pin 11 (RF) and reconnect to pin 15 (RV). At that time the SLIC will revert to constant current feed operation.

Current Limit

The Tip or Ring may accidentally short to ground. In such a case, current will only flow through the feed resistor. This high current will be sensed and reduced by the current limit circuit to a lower value to protect the internal circuitry.

Receive Gain

The MH88612C Receive Gain (VR to 2-wire) can be adjustable by -0.5dB if \overline{GS} is taken logic low or by 0dB if \overline{GS} is taken logic high. When the MH88612C issued with an off hybrid MT896x codec the Receive Gain can be set to either -3.5dB or -7dB by writing to control Register A of Codec and programming \overline{GS} appropriately.

Applications

Component List

R1 = 1/4 W, $\pm 10\%$ 200 Ω

R2, = 1/4W, 5%, 470K Ω

C1 = Cap. Elec., 1.0 μ F, $\pm 10\%$, 25V

D1,D2 = Diode Rect., 200V, 1A, IN4003

K1 = Relay E/M, 5 or 6V, 1 form C

Decoupling capacitors (Cap. Cer 0.1 μ F, 50% + 20%) should be added to V_{DD} , V_{EE} , V_{Bat} , V_{Ref} and V_{RLY} .

Options RV1, RV2= 160 Vrms, 250V 10J

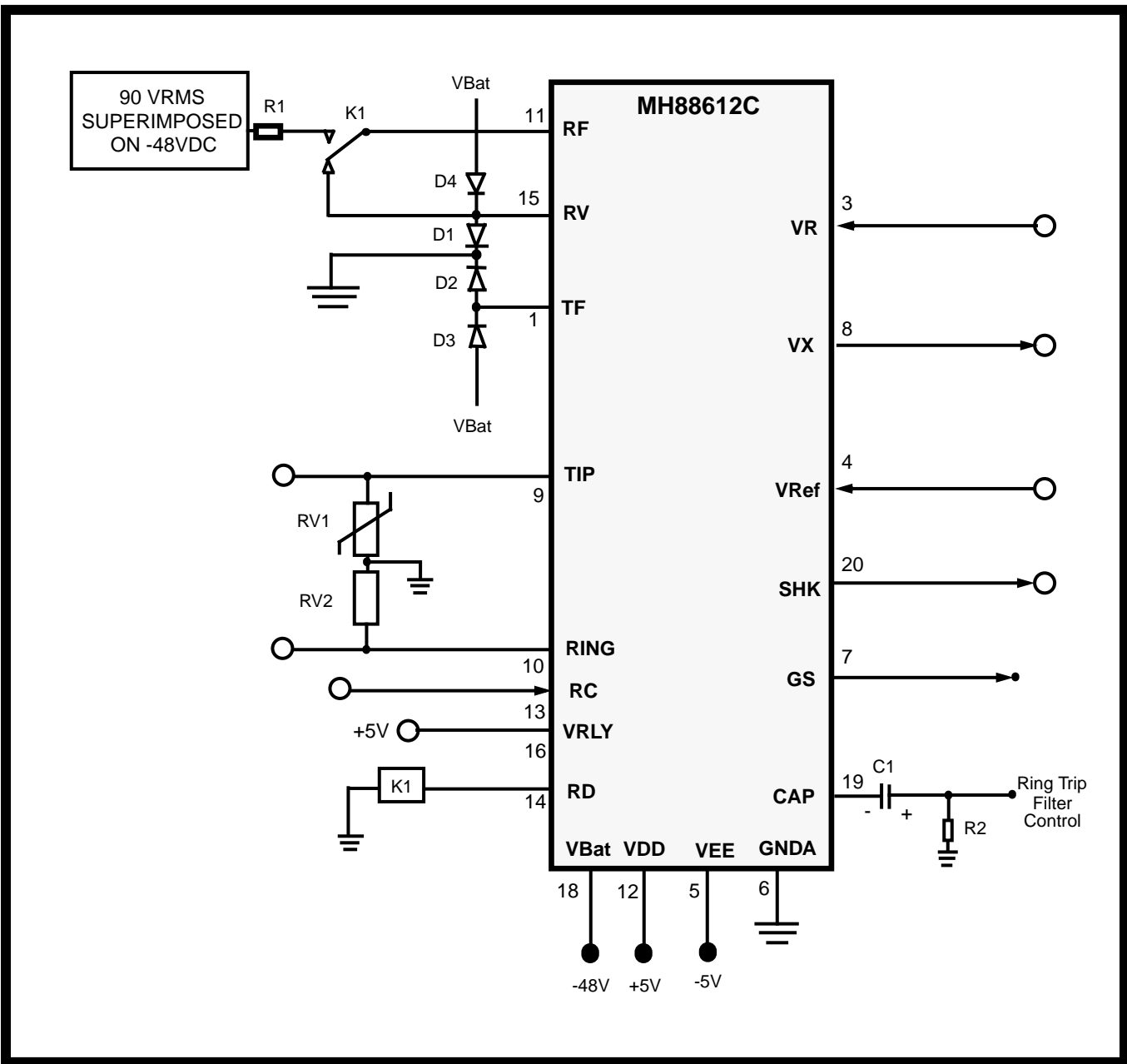

Figure 3 - Application Circuit

Absolute Maximum Ratings*

	Parameter	Symbol	Min	Max	Units
1	DC Supply Voltage	V_{DD}	-0.3	+15	V
		V_{EE}	+0.3	-15	V
		V_{Bat}	0.3	-60	V
2	Storage Temperature	T_{STG}	-40	100	°C
3	Package Power Dissipation	P_D		2	W

* Exceeding these values may cause permanent damage. Functional operation under these conditions is not implied.

Recommended Operating Conditions

	Parameter	Sym	Min	Typ*	Max	Units	Comments
1	Operating Supply Voltage	V_{DD}	4.75	5.0	5.25	V	
		V_{EE}	-4.75	-5.0	-5.25	V	
		V_{Ref}		0		V	Adjustable
		V_{Bat}	-27	-48	-60	V	
		V_{RLY}		5		V	
2	Operating Temperature	T_O	0		70	°C	

* Typical figures are at 25°C and are for design aid only.

DC Electrical Characteristics† - Voltages are with respect to GNDA unless otherwise stated.

	Characteristics	Sym	Min	Typ*	Max	Units	Test Conditions
1	Supply Current	V_{DD} I_{DD}	0.8	5	12	mA	Idle State
		V_{EE} I_{EE}	0.5	3	10	mA	
		V_{Bat} I_{BAT}	0.0	2	2.5	mA	
2	Power Consumption	P_C		210 1410		mW mW	Standby Active
3	Constant Current Line Feed	I_{Loop}	18	21	24	mA	$V_{Ref} = GNDA,$ $V_{Bat} = -48V$
4	Adjustable Loop Current Range	I_{Loop}	18		30	mA	Adjustable with Ext. V_{Ref} input, $V_{Bat} = -48V$
5	Operating Loop Resistance	R_{Loop}			1850	Ω	$V_{Bat} = -48V @ I_{Loop} =$ 18mA, R_{Loop} includes telephone set
6	Ring Ground Over-Current protection				40	mA	
7	Off-Hook Detect Output Low Current (On-hook) Output High Current (Off-hook)	V_{OL}	0.0		0.4	V	Active high logic
		V_{OH}	2.7		5.25	V	
8	Off- Hook Detect Output Low Current (on-hook) Input High Current. (activation)	I_{OL}			8	mA	
		I_{OH}			-400	μA	
9	RC Control Input Input Low Volt. (no activation) Input High Volt. (activation)	V_{IL}			0.7	V	Active high logic
		V_{IH}	2.0			V	
10	RC control Input Input Low Current (no activation) Input high current (activation)	I_{IL}			-50	μA	
		I_{IH}			50	μA	

† DC Electrical Characteristics are over recommended operating supply voltages.

* Typical figures are at 25°C with nominal +/-5V supplies and are for design aid only.

AC Electrical Characteristics

	Characteristics	Sym	Min	Typ*	Max	Units	Test Conditions
1	Ringling Voltage	V_{RING}	40		90 25	V_{rms} Hz	Superimposed on $V_{Bat} = -48V$
2	Ringer Equivalence Number	REN			3		
3	Ring Trip Detect time			100		ms	
4	Input AC Impedance 2-wire (1)	Z_{in}		719		Ω	@1020Hz
5	Input Impedance at V_R			100		$k\Omega$	
6	Output Impedance at V_X			10		Ω	
7	Gain 2-wire to V_X Gain relative to Gain @ 1kHz		-0.5 -0.22	0	0.1 0.1	dB dB dB	Input 3 dBm, 1kHz across Tip and Ring, 300Hz & 3k4Hz 600Hz & 2k4Hz Z_{Load} See Note (1).
8	Gain V_R to 2-wire Gain relative to Gain @ 1kHz with \overline{GS} @ logic high		-0.6 -0.5 0.22	0	-0.4 0.1 0.1	dB dB dB dB	Input 1.0V _{rms} , 1kHz @ V_R with \overline{GS} @ at logic high with \overline{GS} @ at logic low 300Hz & 3k4Hz 600Hz & 2k4Hz Z_{Load} , See Note (1).
9	2-wire Return Loss over 300-3400Hz		20	30		dB	Input 0.5 V _{rms} , across Tip and Ring, Z_{Load} = complex network. See Note (1).
10	Transhybrid Loss over 300-3400 Hz	THL	20	35		dB	Input 0.5V V _{rms} , Z_{Load} = complex network. See Note (1).
11	Longitudinal to Metallic Balance over 300-3400 Hz		46	55		dB	Input 1 V _{rms}
12	Total Harmonic Distortion at V_X at Tip and Ring	THD		0.1 0.1	1.0 1.0	% %	Input 3dBm, 1 kHz across Tip and Ring, Input 1.0 V _{rms} 1kHz at V_R
13	Common Mode Rejection Ratio 2-wire to V_X	CMRR	40	50		dB	Input 1 V _{rms} , 1KHz
14	Idle channel Noise (at V_X) (at T & R)	Nc			14 -76 12 -78	dBrnC dBrnp dBrnC dBrnp	C- Message psophometric C- Message psophometric
15	Power supply rejection ratio V_{DD} V_{EE} V_{Bat}	PSRR	20 20 20	30 30 30		dB dB dB	1 V _{PP} ripple, 1kHz on $V_{DD}/V_{EE}/V_{Bat}$, measure at V_X and across Tip and Ring

* Typical figure are at 25°C and are for design aid only: not guaranteed and not subject to production testing.

Note (1): $Z_{in} = 200 + 560\Omega // 0.1\mu F$

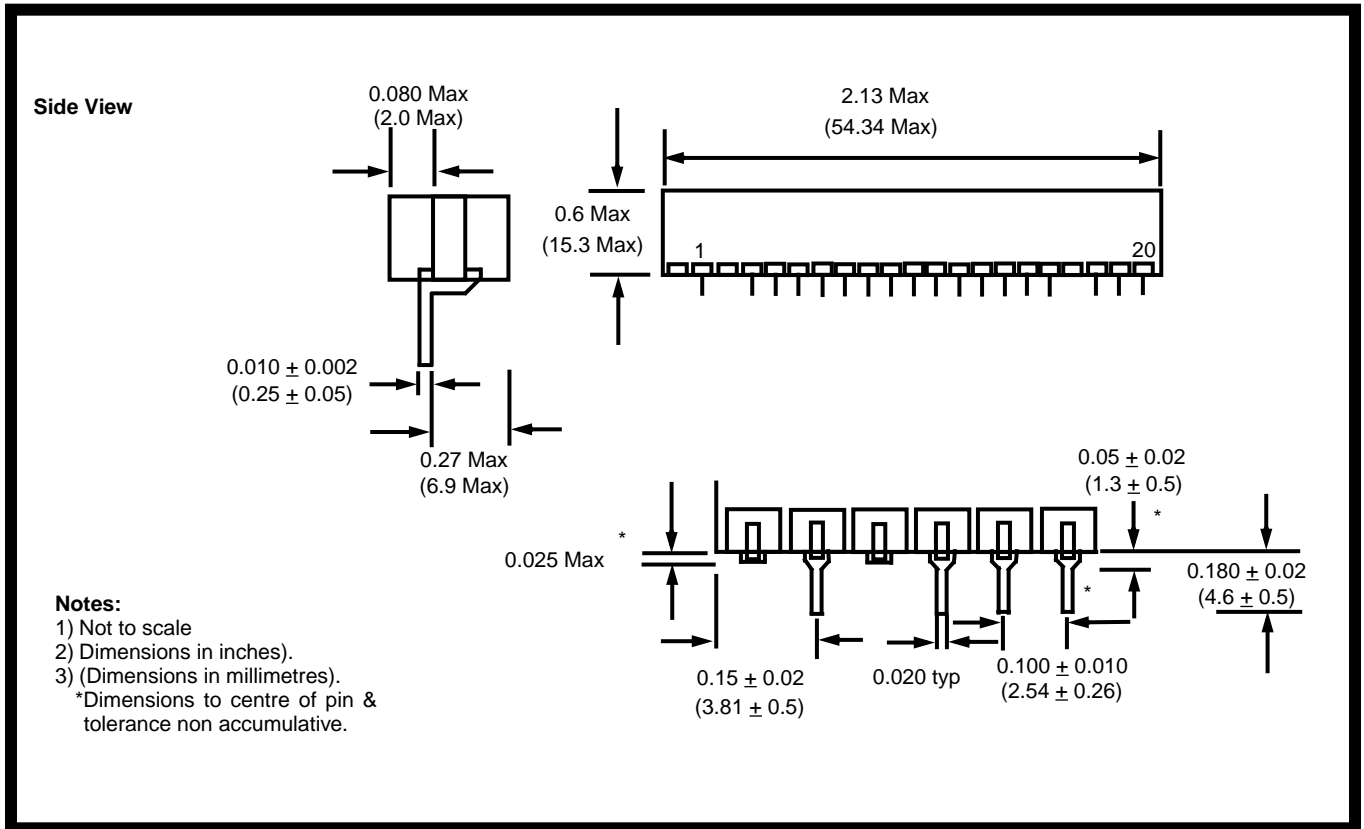

Figure 4 - Mechanical Data

Notes: